

# Contents

	PAGE
<b>1 General Information</b>	2
<b>2 Operation and Safety Instructions</b>	
2.1 Symbols and Terms Used	3
2.2 Important Safety Information	4
2.3 Considerations for Use	5
<b>3 Getting Started</b>	
3.1 Understanding Your Lifter	7
<b>4 Technical Data</b>	
4.1 Model Types	8
4.2 Performance Curves	9
<b>5 Periodic Inspection</b>	10
<b>6 Warranty</b>	10
<b>7 Inspection Record</b>	10
<b>EU Declaration of Conformity</b>	11

# 1 General Information

Thank you for purchasing an Ultralift TP Lifting Magnet from Eclipse Magnetics.

All lifters in this range are tested and rated to provide a 3:1 safety factor if used as instructed by this manual (See Section 3).

This lifter conforms to the requirements of the Machinery Directive 98/37/EU, LOLER regulations (1998) and ASME B30.20.

The equipment, if used within the EU, must be stored, maintained and inspected in accordance with the requirements of PUWER (1998).

For areas outside the EU, the equipment must be used, stored, maintained and inspected in compliance with the applicable work standards and other standards for suspended load handling.

## **BEFORE USE PLEASE CAREFULLY READ THIS MANUAL**

If in doubt call Eclipse Magnetics Customer Care **+44(0) 114 2250600**.

This **Safe Operation and Maintenance Manual** is an integral part of this equipment and should be stored in a safe place in order not to damage or deface it.

It should be retained throughout the lifetime of the lifter.

Should the lifter be resold please ensure the manual is supplied with the lifter.

The lifter should be periodically re-tested in accordance with local legislation and the inspection record updated accordingly (See Section 7).

# 2 Operation and Safety Instructions

## 2.1 Symbols and Terms Used

### SYMBOLS

 The Safe Working Load (Flat Plate)

 Correct orientation of load

 Do not lift people

 Do not lift load over people

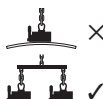
 Do not lift loads exceeding the recommended length

 Air gap warning (See Load Characteristics in Section 4)

### TERMS

**Poles** The parallel mild steel surfaces on the base of the lifter.

**Air-gap** Any non-ferrous material that prevents the poles contacting the load. Paint, rust, scale or even an uneven surface can constitute an air-gap.

## 2.2 Important Safety Information

### **ALWAYS**

- Instruct new operators to read the handbook before using the TP Lifting Magnet
- Follow the instructions
- Use the entire pole area
- Fully engage the lifter in the “ON” position before lifting the load
- Wear suitable protective work-wear when using this equipment
- Maintain the pole feet
- Check the suitability of equipment used in conjunction with the lifter



### **NEVER**

- Lift or transport people
- Lift loads while people are within the manoeuvring space
- Allow untrained personnel to operate the lifter
- Leave a load unattended
- Use the lifter outside the recommended operations
- Attempt to switch the lifter before setting down the load
- Position yourself beneath the lifted load
- Allow the load to sway
- Bring the load to a sharp and immediate stop
- Lift a load outside the capacity (SWL) of the lifter
- Lift a load with dimensions outside those recommended within this manual
- Alter the attitude of the load from horizontal to vertical
- Lift an unbalanced load
- Operate the lifter in temperatures higher than 80°C (176°F) and lower than -10°C (14°F)
- Operate the lifter in humidity higher than 80%
- Operate the lifter in explosive (EX) or static sensitive environment
- Submerge the lifter in water

## 2.3 Considerations for Use

The TP Lifting Magnet has been specifically designed for the handling of mild steel plates with a thickness of less than 10mm.

The SWL data displayed on the lifter is based on two thicknesses of material, 5mm and 10mm. This data has been generated testing the TP Lifting Magnet on a flat ground mild steel plate.

For the SWL on other material thickness please refer to the information in shown in Section 4 of this manual.

The optimum performance of a magnetic lifter is achieved when the pole faces are in good condition and make intimate contact with a load of the recommended thickness.

Consideration should always be made to the size of the load (Section 4 Technical Data).



### **WARNING**

**Whilst the load weight may be within the SWL of the lifter, as the unsupported area of the load increases, natural flexing will occur due to its own weight. This could have an adverse effect on the safety of the lift. If in doubt always use a spreader beam and multiple lifters.**

**There are four factors that will reduce the magnetic clamping force:**

#### **1 Air Gaps**

The high magnetic forces generated by the TP Lifting Magnet allow the lifter to clamp components through air gaps. However, air gaps will ALWAYS have an adverse effect on the lifter performance. Air gaps are generated in a number of ways, for example, paint, dust, scale or even a poor surface finish constitutes an air gap.

The effect of air gaps are shown in Section 4 of this manual. These graphs demonstrate the reduction in clamping force generated by the lifter as the air gap increases.

#### **2 Load Thickness**

Standard Magnetic Lifters will clamp thin plate section, however, performance is greatly reduced and, because the lifter is designed to clamp thicker material, stray magnetic flux can result in the lifter attempting to clamp multiple plates. For instance, a typical 250kg lifter will lose over 20% of the stated performance on 10mm thick material. As the material reduces in thickness so does the clamping force.

The three-pole design of the TP Lifter is specific for thin plate lifting providing excellent clamping forces on materials less than 10mm. Performance figures are shown in Section 4 (Technical Information) of this manual.

### 3 Material Types

Certain materials exhibit different characteristics in their ability to carry magnetism. For any material other than mild steel a reduction factor must be applied to calculate the clamping force.

Typically these are as follows: -

Ferrous alloy steels	<b>0.8</b>
High carbon steel	<b>0.7</b>
Cast iron	<b>0.55</b>

For example: mild steel SWL 150kg = cast iron 150kg × **0.55** = SWL 83kg

### 4 Contact Area

Maximum hold will only be achieved when the lifter has full contact area with the component to be lifted. If the full face of the poles does not come into contact with the component to be lifted, for instance due to holes in the component, the performance will be reduced pro-rata.

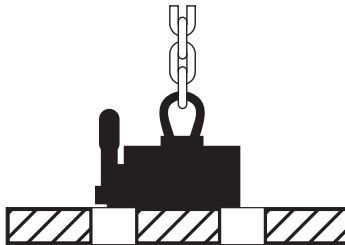

# 3 Getting Started

**It is important to familiarise yourself with the operation of the TP Lifting Magnet prior to use in a production environment.**

The TP lifting magnet is delivered ready for use.  
Remove the lifter from the packaging and position on a mild steel plate (load). Care should be taken to ensure the load does not exceed the stated capacity of the lifter.

## 3.1 Understanding Your Lifter



**The lifter is in the OFF position**



**To Switch the lifter ON**

Rotate the handle 120° anti-clockwise.  
Ensure the lever is securely locked in place before commencing with the lift.



**The lifter is in the ON position**



**To Switch the lifter OFF**

Return the load to the floor or support.  
Depress the plunger on the handle and rotate 120° clockwise to its stop position.



**Release the plunger to complete the switching process**

# 4 Technical Data

## 4.1 Model Types

Model No	Self Weight (kg)	Dimensions (mm)						Material Thickness (mm) 5		Material Thickness (mm) 6		Material Thickness (mm) 8		Material Thickness (mm) 10	
		A	B	C	D	E	F	SWL (kg)	Length Max (mm)	SWL (kg)	Length Max (mm)	SWL (kg)	Length Max (mm)	SWL (kg)	Length Max (mm)
		TP150	8	202	150	181	100	126	74	75	1500	100	1500	150	1500
TP300	15	352	300	181	100	126	74	150	2000	200	2000	300	2000	400	2000

Model No	Self Weight (lb)	Dimensions (inches)						Material Thickness (inches) 0.20		Material Thickness (inches) 0.24		Material Thickness (inches) 0.31		Material Thickness (inches) 0.39	
		A	B	C	D	E	F	SWL (lbs)	Length Max (inches)	SWL (lbs)	Length Max (inches)	SWL (lbs)	Length Max (inches)	SWL (lbs)	Length Max (inches)
		TP330	18	8	6	7	4	5	3	165	60	220	60	330	60
TP660	33	14	12	7	4	5	3	330	80	440	80	660	80	880	80

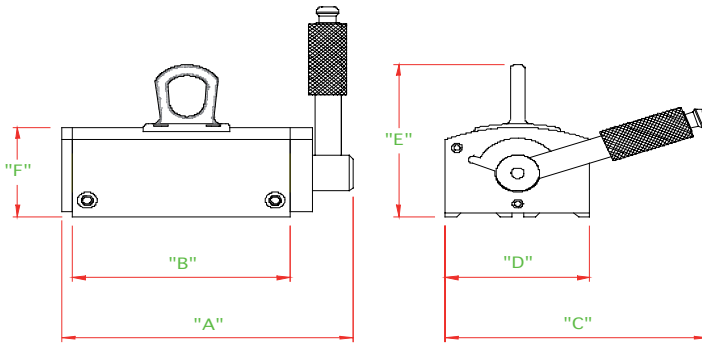



## 4.2 Performance Curves

### TP150 (TP330)

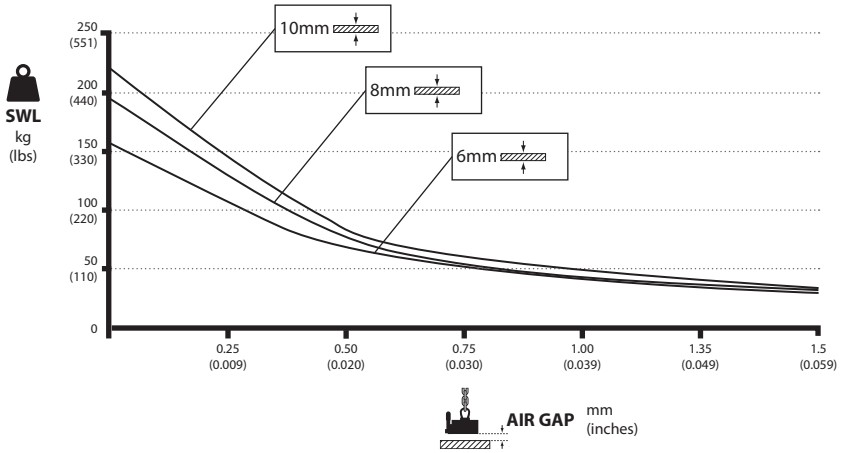

### TP300 (TP660)

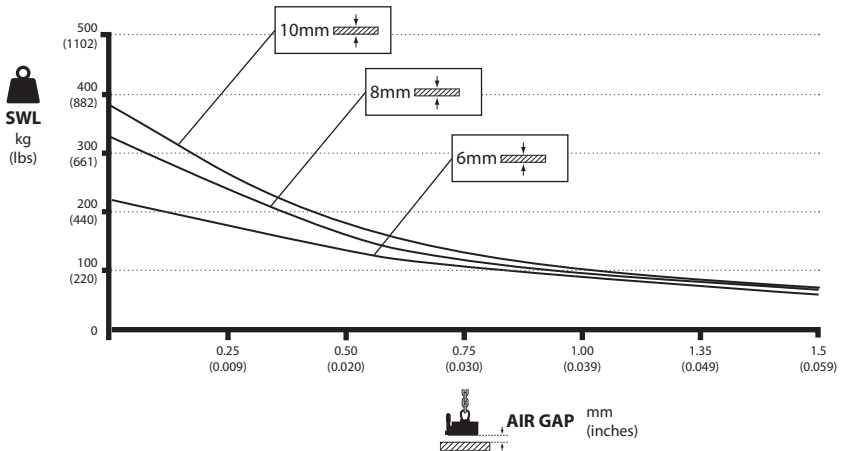

# 5 Periodic Inspection

If the Magnetic Lifter is being used in the EU then it must be inspected and maintained in accordance with the requirements of PUWER (1998).

For areas outside the EU, the Magnetic Lifter must be inspected and maintained in compliance with the applicable work standards and other standards for suspended load handling.

Should the data plates become detached or damaged please contact Eclipse Magnetics immediately for replacement plates. In addition to statutory requirements Eclipse Magnetics recommend the following:

## MAINTENANCE SCHEDULE

Operation	Frequency			
	Daily	Weekly	Monthly	Annually
Inspect pole feet for damage	✓			
Inspect lifting eye for damage and security		✓		
Inspect data plates for damage			✓	
Proof test SWL				✓

# 6 Warranty

The TP Lifting Magnet is covered by a 3-year warranty from the date of invoice and is subject to the Eclipse Magnetics standard terms and conditions of sale, a copy of which is available on request.

# 7 Performance Test Record

Your TP Lifting Magnet should be re-certified in accordance with the requirements of PUWER (1998) and LOLER (1998).

For areas outside the EU the TP Lifting Magnet must be inspected in compliance with the applicable work standards and other standards for suspended load handling.

It is recommended that this inspection be carried out at an Eclipse Magnetics service centre.

# EU Declaration of Conformity

## Product Description

Manually switched permanent lifting magnet

## Product Identification

Ultralift Thin Plate Lifter range identified as :

TP150, TP300

Eclipse Magnetics Ltd  
Units 1-4 Vulcan Rd  
Sheffield  
S9 1EW  
England

We hereby declare that the product below has been declared in conformity with provisions of the following directives:

- **Machinery Directive 98/37/EU**
- **BS EN ISO 12100-1 Basic engineering principles**
- **BS EN 13155:2003 Cranes safety: non-fixed load lifting attachments**
- **SS7665601 Swedish standards for magnetic lifting devices**
- **ASME B30.20**



*Kevin Martin*  
*Engineering Director*