

PERMANENT MAGNETIC CHUCKS

Magnetic chucks are used for holding iron pieces, especially in the machining industry. Their operation is based on magnetism, which depending on the type of chuck, is created with permanent magnets, electromagnets or a combination of both. Selter permanent magnetic chucks are made with magnets which have a high resistance to demagnetisation thereby guaranteeing a long working life for the chuck under normal working conditions.

The use of magnetic chucks in different machining operations provides a wealth of advantages for greater productivity.

- A reduction in tooling costs and machine preparation time.
- A reduction in the time needed to load and unload pieces.
- Maximum access to the piece due to the absence of clamps and fixing devices
- Greater precision in the flatness of the pieces.

In the range of Selter magnetic chucks there are special types for different machining operations and machines, for example: grinding machines, milling machines, lathes and spark erosion machines. The magnetic chucks are divided into the following types:

- FI-POL, EXTRAFINE POL for small, narrow pieces
- MAX-POL, for milling
- Circular magnetic chucks

The type of chuck chosen depends largely on the machine and the operation to be carried out but additionally on the characteristics of the piece. The size, shape, material and surface conditions of the piece are all factors affecting the holding force and must be taken into account before using a magnetic chuck.

SIZE AND SHAPE

The size of the piece is important to determine the distance between the magnetic poles of the chuck (pole spacing). In general it could be said that for large pieces a large pole spacing is needed and for smaller pieces a narrower pole spacing is more adequate. Various accessories, including flux transmission blocks, magnetic blocks or supports help holding pieces with different sizes for most jobs.

MATERIAL

Pieces to be hold for a chuck must be made of iron. A pure iron material has better magnetic properties than a steel alloy. For this reason, an increase in the alloying material diminishes the holding force (fig. 1).

SURFACE CONDITIONS

The condition of the contact surfaces of both the chuck and the piece are also important for an optimum magnetic hold. A separation (air gap) between the piece and the chuck impedes the flow of the magnetic flux and the holding force is therefore reduced. The maximum holding force exists when the surfaces are perfectly ground and clean. Dirt, protuberances, holes or a rough surface diminish the effectiveness of the magnetic holding. (fig. 2).



HOLDING FORCE

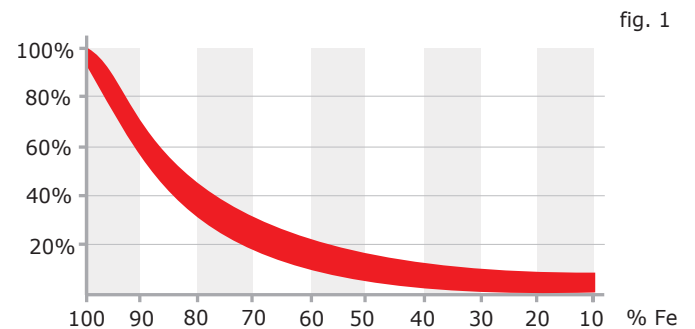

HOLDING FORCE

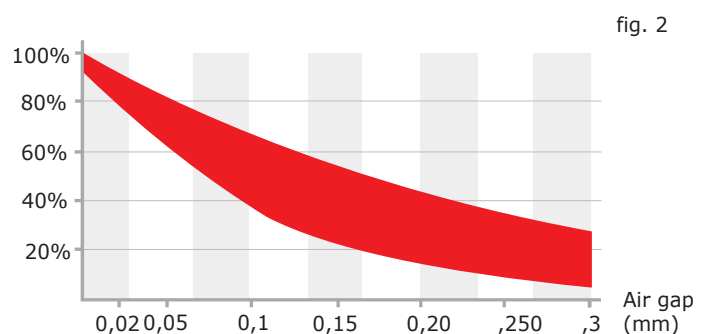

FI-POL MAGNETIC CHUCKS, FOR GRINDING

These chucks are ideal for grinding different kinds of pieces, and give good results with small, narrow pieces. They are completely coolant-tight and oil-tight and can operate totally submerged in these liquids.

Magnetisation is carried out via the lever, and chucks with lengths over 600 mm have 2 levers. The shaft on smaller chucks does not project from the chuck and can be handled using the Allen key supplied.

The clamps used to hold the chuck are supplied separately and must be ordered expressly.

Available in pole format: Fi-Pol



FI-POL

It has a narrower pole spacing: 6-1.5-2-1.5 (6 mm of steel, 1.5 of brass, 2 of steel and 1.5 of brass).

It has greater holding power for small or narrow pieces (less than 3 mm), and for larger pieces, it gives a similar result to Nor-Pol.

Clamping force: 80 N/cm²

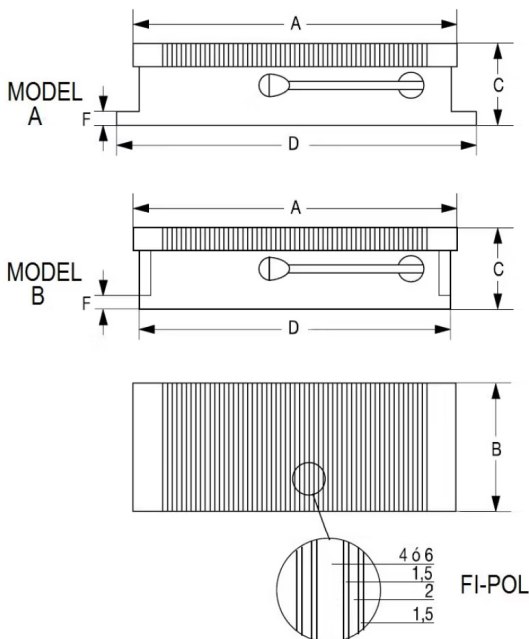

CODE	A mm	B mm	C mm	D mm	F mm	LEVERS	MODEL	WEIGHT Kg
12.10.004	100	65	54	119	10	1*	A	3
12.10.001	150	102	65	165	15	1*	A	7
12.12.001	250	150	65	258	15	1*	A	15
12.12.003	350	150	65	358	13	1*	A	21
12.13.002	400	200	72	413	15	1	A	32
12.13.004	500	200	72	515	15	1	A	40
12.15.004	600	300	93		20	1	B	100

* The shaft does not project from the chuck and can be handled using an Allen Key
Other dimensions under request.

MAX-POL MAGNETIC CHUCKS / FOR MILLING

With a more robust construction and greater magnetic power, this chuck is designed for use with milling machines.

Its pole spacing of 8-5 (8 mm of steel and 5 of brass) is suitable for all kinds of pieces with thicknesses of 5 mm to the very largest pieces.

Clamping force: 120 N/cm²

It is completely coolant-tight and oil-tight and can operate totally submerged in these liquids.

Magnetisation is carried out via the lever, chucks with lengths over 600 mm have 2 levers.

The clamps used to hold the chuck are supplied separately and must be ordered expressly.

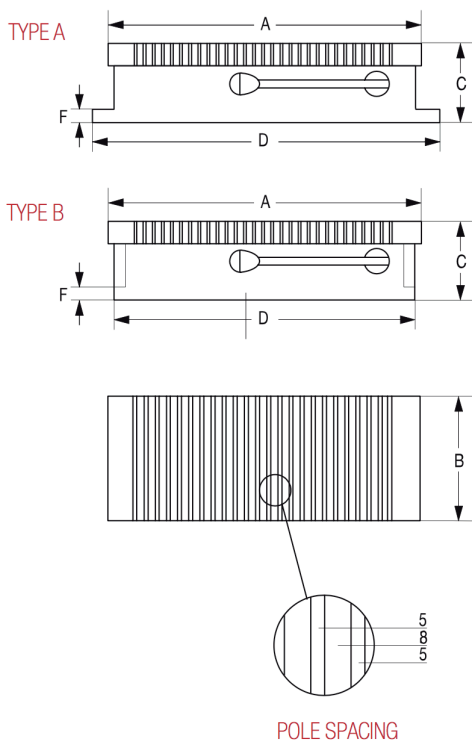

CODE	A mm	B mm	C mm	D mm	F mm	LEVERS	TYPE	WEIGHT Kg
12.22.001	250	150	92	260	20	1	A	20
12.22.003	350	150	92	360	20	1	A	27
12.22.005	450	150	92	460	20	1	A	34
12.23.002	400	200	92	395	20	1	B	40
12.23.004	500	200	92	495	20	1	B	50
12.23.005	600	200	92	595	20	1	B	62
12.25.002	500	300	92	495	20	1	B	90
12.25.003	600	300	92	595	20	1	B	100
12.25.004	800	300	92	795	20	2	B	130
12.25.006	1.000	300	92	995	20	2	B	180

Other dimensions under request.

MAGNETIC CHUCKS WITH EXTRAFINE POLE

This chuck is very low (40 mm) and has very fine pole spacing of 1.5-0.8 (1.5 mm of steel and 0.8 of brass).

It is suitable for very small or narrow pieces on grinding or sparkerosion machines.

Clamping force: 80 N/cm²

It is completely coolant-tight and oil-tight and can operate totally submerged in these liquids.

The magnetisation shaft does not project from the chuck and can be handled using the Allen key supplied.

The clamps used to hold the chuck are supplied separately and must be ordered expressly.

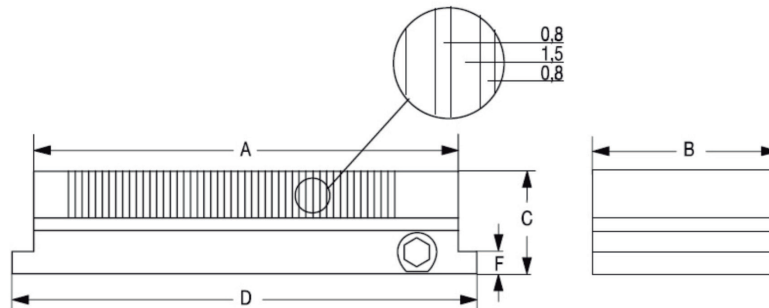

CODE	A mm	B mm	C mm	D mm	F mm	WEIGHT Kg
12.50.001	150	100	40	165	10	5
12.50.003	200	100	40	215	10	6,5
12.52.008	150	150	40	165	10	7,5
12.52.001	250	150	40	265	10	12
12.52.002	300	150	40	315	10	14,5
12.52.003	350	150	40	365	10	17
12.52.004	400	150	40	415	10	19,5
12.52.005	450	150	40	465	10	22

Other dimensions under request.