

# Circular Grid Magnet

High Intensity – Rare Earth



Data Sheet No 503

## Product Data:-



### **Preface:**

The Eclipse high intensity circular grid is very versatile and can be utilised in most powder, granulate & liquid applications for the removal of ferrous and paramagnetic contamination down to sub micron in size.

These units can be manufactured to any size and with any number of rods to meet most application requirements. Due to the grids low profile side frame these units can be installed into existing pipelines or feed hoppers.

Grids are of particular interest to OEM's who wish to incorporate them into their machinery with the minimal amount of re-design and also offering flexibility.

### **Cleaning:**

Due to the high intensity magnetic field, and simple design fixed grids require more effort to clean than the Eclipse 'Easy Clean' design. Remove the grid from it's process position and using a gloved hand push the contamination down each rod which will release the majority of all attracted contamination. For any remaining contamination sticky tape can be used to remove the remaining or very fine contaminants.

### **Suitable Products:**

Dry powders and granulates.

### **Suitable Locations:**

Any vertical or slightly angled process line.

### **Benefits:**

- Simple to install
- Reduces 'spark' risk
- Removes sub micron sized contaminants
- Meet audit requirements
- Rare Earth 9,000 Gauss

### **Category:**

Secondary.

# Circular Grid Magnet

High Intensity – Rare Earth



## Technical Data:-

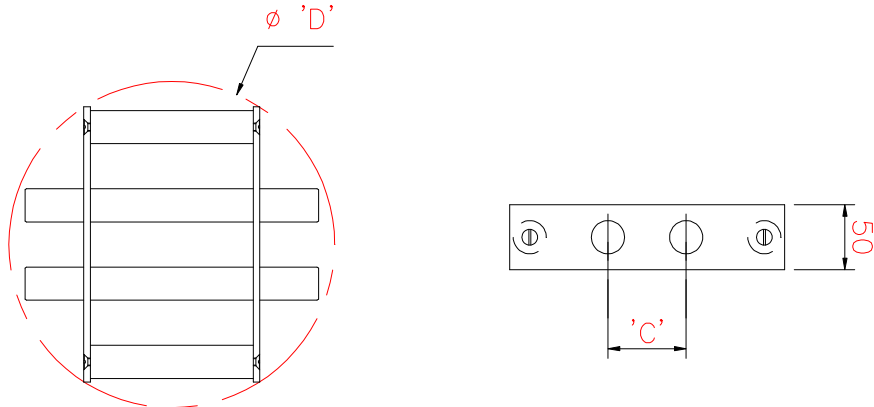

### Sizes:-

Part No	Dia D	Centres C	No. Rods	Weight Kgs
CG100	100	45	2	1.2
CG150	150	50	3	1.5
CG200	200	60	3	2.2
CG250	250	60	4	3.7
CG300	300	60	5	5.0
CG350	350	60	6	7.0
CG400	400	60	7	9.5
CG450	450	60	7	14
CG500	500	60	8	17

All dimensions in mm

### Performance:-

#### Magnetic Performance:

7,000 Gauss - Standard Strength  
9,000 Gauss - High Strength  
11,000 Gauss – Super High Strength

#### Performance Reading:

On tube surface

#### Magnetic Material:

Rare Earth Neodymium Iron Boron

#### Magnet Grade:

N35 & N45 – Inspected & confirmed via hystergaph prior to use

#### Temperature:

-20° C/ + 90° C

### Materials:-

#### Grid Frame:

316 Grade Stainless Steel

#### Tubing:

316 Grade Stainless Steel – Aerospace Quality

#### Other Parts:

316 Grade Stainless Steel

#### Surface Finish:

Polished to 0.6µm

### Options:-

High temperature Samarium Cobalt magnetic material + 250° C

Sizes up to 1000mm Ø

Pharmaceutical specification

Safety relay switch

ATEX certified

Eclipse Magnetics Ltd - A Spear & Jackson Group Company

Atlas Way, Atlas North, Sheffield, S4-7QQ, England

Tel:- ++44 (0)114 225 0555 Fax:- ++44 (0)114 225 0525

e-mail enquiries@eclipse-magnetics.co.uk - Web Site www.magneticseparation.co.uk

Copyright Eclipse Magnetics 2008

