

High Pressure – Rare Earth

Product Data

Data Sheet No 405



The Micromag HP50 has all the same benefits of the standard Micromag but has been developed to suit high pressure through-spindle-coolant applications, where the smallest of particles can damage seals, spindles and even reduce the efficiency of the cutting tool.

Micromag HP50 can be installed anywhere in the fluid delivery system and will ensure that even sub-micron magnetic and para-magnetic particles are removed before they can cause any expensive damage.

For further information relating to the benefits and operation of the Micromag HP50 please refer to the supplied standard Micromag brochure.



Cleaning

Using the supplied cleaning tool, a fully contaminated core can be cleaned in under 30 seconds. Only metallic particles are removed from the filter and these can be easily disposed. There are no dirty cartridges!

Suitable Products

Neat and soluble oils.

Installation Location

Pre- or post-pump, delivery line, spindle feed or pre-membrane cartridge.

Benefits

- High pressure
- Sub micron filtration
- Large holding capacity
- High intensity rare earth magnetic material
- Suitable for all machining applications
- Environmentally responsible
- No consumables

Category

High pressure.

High Intensity - Rare Earth

Technical Data

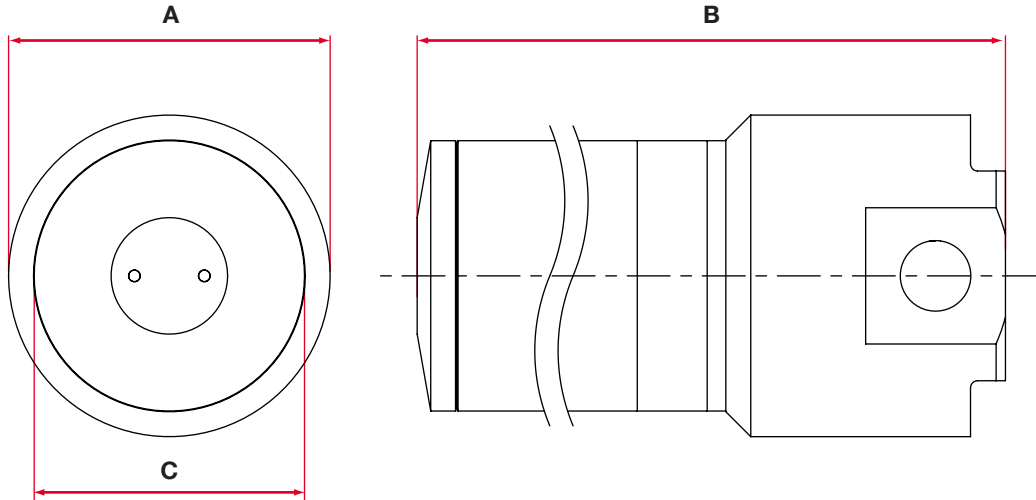

Sizes

Part No	Dia A	Height B	Dia C	Port Size	Capacity (kgs)	Max Flow Rate (ltrs/min)
MM5/HP/50	138	247	116	1" BSP	1	70
MM10/HP/50	138	365	116	1" BSP	2	100
MM20/HP/50	138	625	116	1½" BSP	4	150

All dimensions in mm

Performance

Maximum Pressure	50 Bar
Magnetic Performance	High intensity
Magnet Grade	N45 – Inspected & confirmed via hystergaph prior to use
Temperature	5°–140°C

Materials

Housing	Aluminium
Lid	Aluminium
Tube	304 Grade stainless steel
Surface Finish	Machined and anodised
Sealing	Viton O-ring

Options

- Core cleaning post
- Mounting bracket
- Port adaptors